

# OKR124

## 24" Keg Refrigerator • Outdoor Collection



Single Tap Accessory



Double Tap Accessory

### Key Features

- Convection cooling system provides a quick cool down and consistent temperature
- Digital Touch Pad Control with blue LED display
- Stainless steel cabinet, toe-kick, and full-wrap door
- Volume of 5.5 cu ft can fit up to one ¼ slim barrel and one ⅙ barrel or one standard ¼ barrel
- Holds up to 111 bottles (12 oz) or 165 cans (12 oz)
- Temperature range: 34°F - 60°F
- Bright white LED lighting
- White interior
- Removable lower interior stainless steel liner
- Two adjustable chrome plated wire shelves
- Stainless steel handle (7/8" diameter)
- Field reversible door is shipped right-hand hinged
- Built-in or freestanding
- Four adjustable leveling legs
- Accessory Tap Tower Kits include: Low profile tap head(s), CO2 tank and regulator, tubing and clamps, mounting hardware, black tap handle(s), drip tray, and cleaning kit

### Model Details

Model	Voltage/Hz	Door Swing	Finish	Shipping Weight
UOKR124-SS01A	115 / 60	Field Reversible	Stainless Solid	117 lb

### ACCESSORIES

Model	Description	Finish	Shipping Weight
ULAFREESTANDS	Freestanding Kit	Stainless	3 lb
ULATAP SINGLE	Single Tap Tower Kit	Stainless	20 lb
ULATAP DOUBLE	Double Tap Tower Kit	Stainless	24 lb

### Dimensions

#### Front

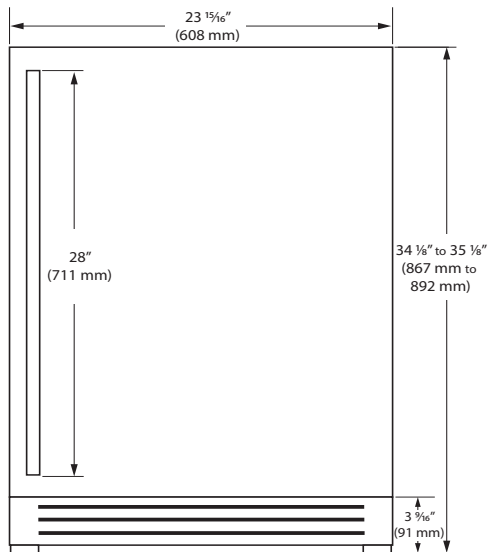

#### Side

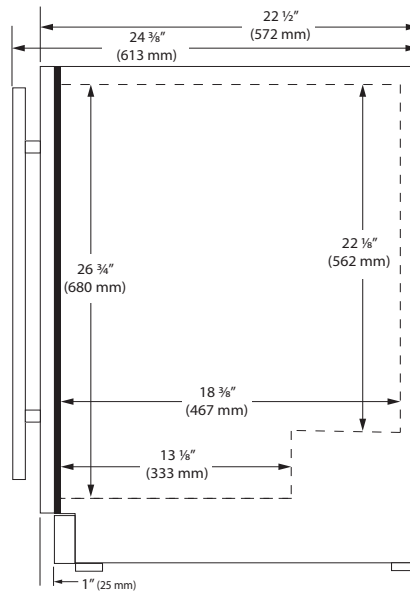

#### Top

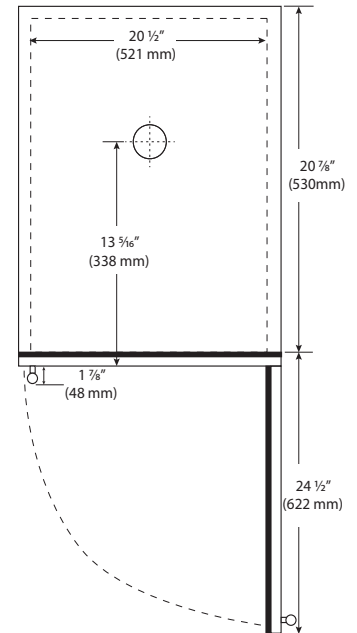

### Specifications

Model	OKR124
Amps: Running	1.2
Capacity: Bottle (12 oz)	111
Capacity: Can (12 oz)	165
Capacity: Volume (cu ft)	5.5
Capacity: Wine Bottle (750 ml)	N/A
Dimensions: Product Depth	22 1/2" / 572 mm
Dimensions: Product Height	34 1/8" / 867 mm
Dimensions: Product Width	23 15/16" / 608 mm
Energy Consumption: Avg. Per Year	240 kWh
ENERGY STAR	Tier 3
Product Weight: Max	117 lb
Refrigerant Type:	R600a
Sabbath (Star K Certified)	Yes
Temperature Range	34°F - 60°F

#### Back

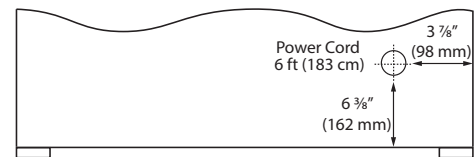

#### Cabinet Cut-Out

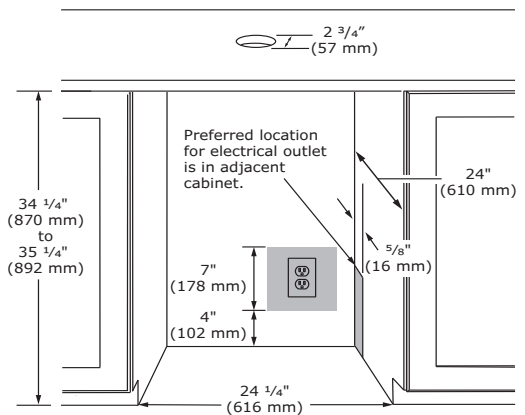

### Warranty

- 1 Year (parts & labor) / 5 year sealed system (parts)
- **2 Year (parts & labor) / 5 year sealed system (parts) upgrade at no cost with product registration**



See complete warranty for details

### Installation Notes

- 24" cutout width sufficient if door protrudes beyond adjacent cabinetry
- No additional clearance is needed for ventilation
- Do not obstruct front grille air flow

